

8146/5-6 Series Disconnects

DISCONNECT SWITCHES FOR HAZARDOUS & CORROSIVE ENVIRONMENTS



DISTRIBUTION

STAHL

Disconnects 8146/5-6 Series Features:

- 16A, 32A, 63A and 125A models.
- Enclosures made of Fiberglass Reinforced Polyester (FRP) with recessed gasket and captive stainless steel cover screws.
- 3 pole (plus auxiliary) horsepower rated switch.
- Increased safety terminals and integrated ground bar.
- Large grip, lockable handle.
- Multiple entry methods available (see section J).
- No seals required for Division 2 application.

Distribution **H-9**

8146/5-6 Series Disconnect Switches H1-H3
8145/5 Series Breaker Panels H4-H9

Our products are updated to the newest standard developments and technologies which makes it necessary to reserve the right to product changes without notice.





8146/5-6 Series DISCONNECTS

DISCONNECT SWITCHES FOR
HAZARDOUS & CORROSIVE ENVIRONMENTS

CLASSIFICATIONS

NEC- Class I, Zone 1 AEx de IIC T6†
Class I, Division 2, Groups A,B,C,D
Class II, Divisions 1 and 2,
Groups E,F,G
Class III
Enclosure 3, 4, 4x, IP66
File No. J.I. 2Q0A4.AX
J.I. 2X5A0.AE



†Zone 1 Approval Applied for

CEC- Class I, Zone 1 Ex de IIC T6
Class I, Division 2, Groups A,B,C,D
Class II, Divisions 1 and 2
Groups E,F,G
Class III
File No. L.R. 99468



II 2G Ex ed IIC T6
Zone 1 & 2
Ingress Protection IP66
PTB 01 ATEX 1024

Ambient Temperature Range
+40°C (+104°F) Max.
-20°C (-4°F) Min.

Special Temperature Range*
+55°C (+131°F) Max.
-40°C (-40°F) Min.
*Consult Factory

Applications

The DISCONNECTS 8146/5-6 series are horsepower rated for motor load applications. While the product is load rated, no short circuit protection is designed into the switch.

To provide adequate short circuit protection, properly sized Class J fuses must be installed in the circuit upstream from the switch.

Due to the design of the switch, no external sealing fittings are required for Class I, Division 2 applications. Some Class II applications may require installation of seals. Consult the National Electrical Code Article 502-5 or the Canadian Electrical Code Section 18 (154) for specific instructions.

STAHL offers the DISCONNECT Series 8146/5-6 constructed to meet the most demanding environments. The Disconnect 8146/5-6 Series provides safety in hazardous and corrosive locations.

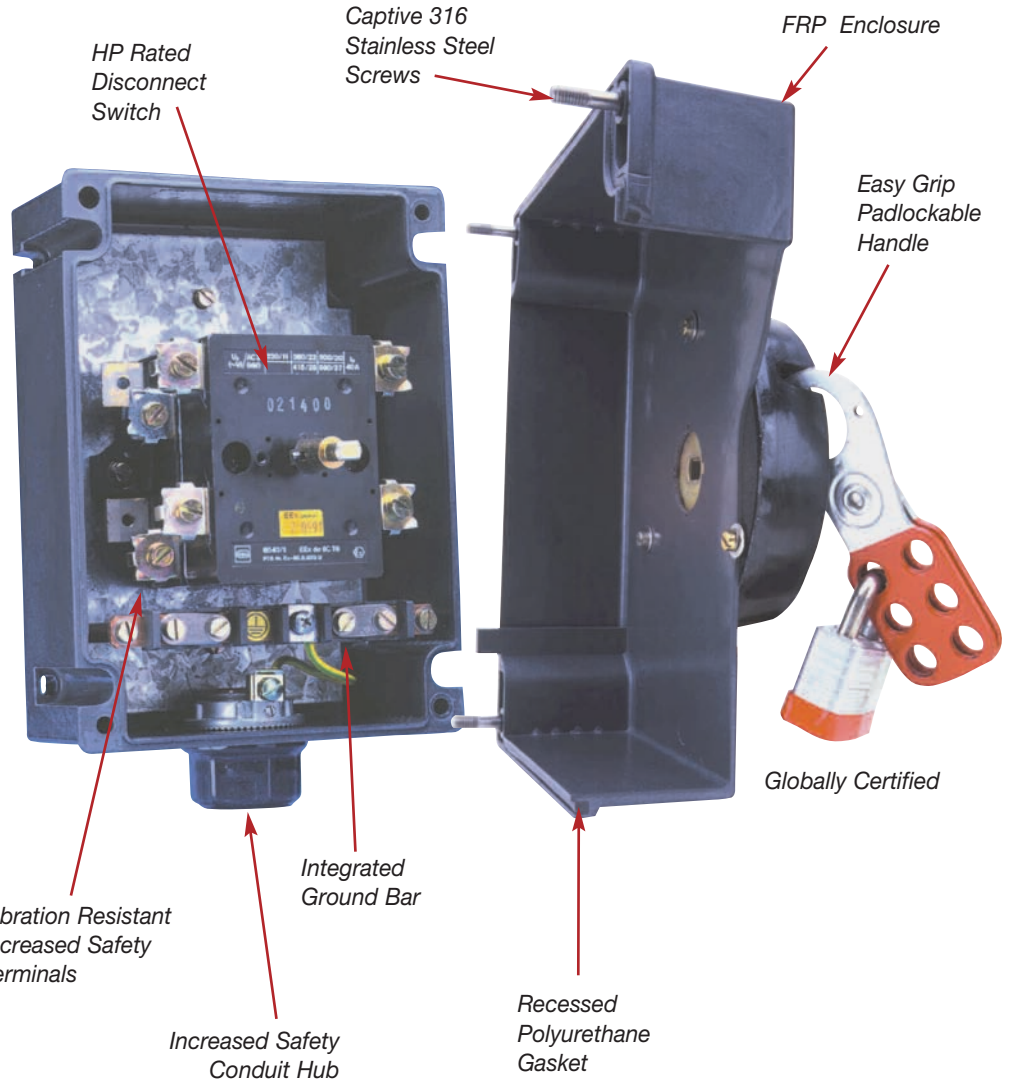

Technical Data

		16 AMP.	32 AMP.	63 AMP.	125 AMP.
RATED VOLTAGE	AC	600	600	600	600
RATED VOLTAGE	DC	220	-	-	-
HORSE POWER	600VAC	10	30	60	125
	480VAC	10	20	40	100
	240VAC	5	10	20	40
	120VAC	2	5	10	20
TERMINALS	AWG	12	4	2	4/0
	STRANDED (mm ²)	2.5	16	25	95
	SOLID (mm ²)	-	25	35	120
BACK-UP FUSE (Required)	Class J	20 MAX	40 MAX	100 MAX	200 MAX



8146/5-6 Series DISCONNECTS

DISTRIBUTION

DISCONNECT SWITCHES FOR
HAZARDOUS & CORROSIVE ENVIRONMENTS



- A - 16 AMP DISCONNECTS SERIES
- B - 32 AMP DISCONNECTS SERIES
- C - 63 AMP DISCONNECTS SERIES
- D - 125 AMP DISCONNECTS SERIES

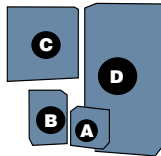

Installation Example

8146/5-6 Disconnect Logic

8146/5-6		HUBS
02 - 16 AMP	000 - NO HUBS 001 - 1/2" NPT 002 - 3/4" NPT 003 - 1" NPT 004 - 1-1/4" NPT 005 - 1-1/2" NPT 006 - 2" NPT 007 - 2-1/2" NPT 008 - 3" NPT	
04 - 32 AMP		
06 - 63 AMP		
09 - 125 AMP		
0 - NO ENTRY		COMPRESSION CABLE GLANDS (CABLE O.D.)
3 - TOP FEED ENTRY		M16 .20" - .30"
4 - BOTTOM FEED ENTRY		M20 .25" - .50"
5 - FEED THROUGH ENTRY		M25 .50" - .67"
6 - 2 TOP ENTRIES		M32 .40" - .70"
7 - 2 BOTTOM ENTRIES	M40 .65"- 1.00"	
	M50 .91"- 1.25"	
	M63 1.26"- 1.73"	

Ordering Information

CATALOG NUMBER			AMP.	HUB SIZE	ENCLOSURE
WITHOUT HUBS	FEED THROUGH ENTRY (Top & Bottom)	FEED THROUGH ENTRY (2 Hubs In Bottom)			
8146/5-602-0000	8146/5-602-5002	8146/5-602-7002	16	3/4"	8146/5052-D
8146/5-604-0000	8146/5-604-5003	8146/5-604-7003	32	1"	8146/5062-B
8146/5-606-0000	8146/5-606-5006	8146/5-606-7006	63	2"	8146/5083-D
8146/5-609-0000	8146/5-609-5007	8146/5-609-7007	125	2 1/2"	8146/5095-B

Modifications of the standard designs are possible e.g. auxiliary contacts entry parts, additional terminals.



INNOVATIVE EXPLOSION PROTECTION by R. STAHL 1-800-782-4357

DIMENSIONS

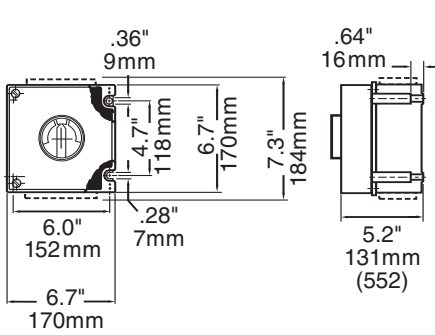

16A DISCONNECT SWITCH
8146/5-602 Series

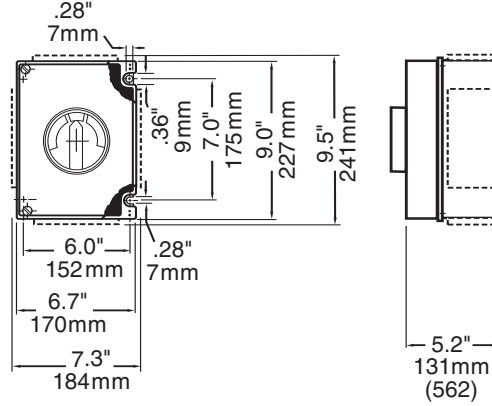

32A DISCONNECT SWITCH
8146/5-604 Series

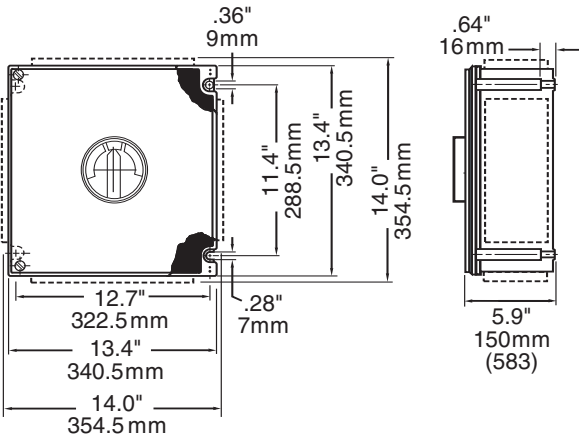

63A DISCONNECT SWITCH
8146/5-606 Series

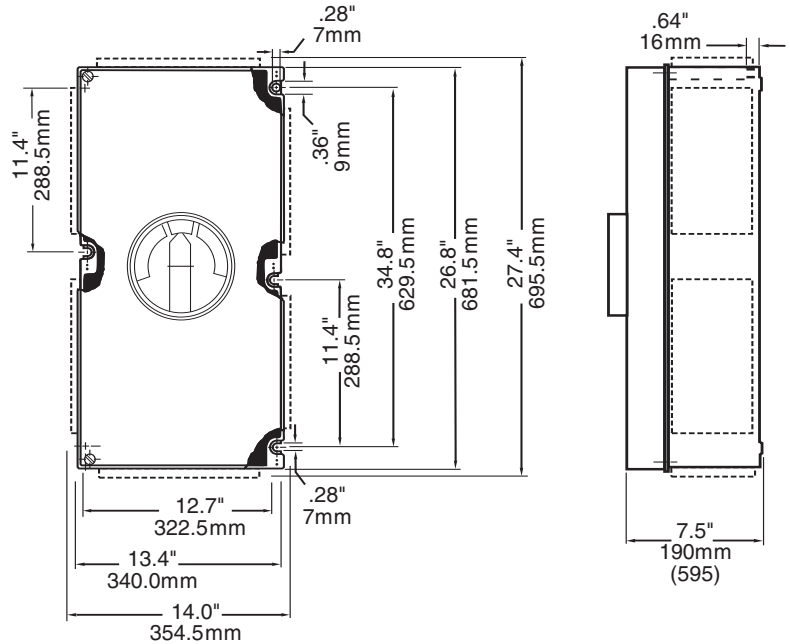

125A DISCONNECT SWITCH
8146/5-609 Series

8146/5 Series Breaker Panelboards

BREAKER PANELBOARDS FOR HAZARDOUS & CORROSIVE ENVIRONMENTS



DISTRIBUTION

STAHL

Breaker Panels

Features:

- Wide variety of Flameproof branch circuit breakers for Zone 1 & Division 2 to UL 489 & CSA C22.2 No. 5
 - Thermal-magnetic branch circuit breaker protection, 40A max.
 - Mounted under hinged window flaps for easy actuation.
 - Shunt trips (optional).
 - Lockout on breaker and window flap.
 - Line and load side factory wired to “increased safety” terminals, ready for field connections
- Flameproof main disconnect switches 125A max. with lockout provision (optional).
- FRP “increased safety” enclosures
 - Suitable for wet and corrosive locations
 - Impact resistant
 - Light weight
 - Wall mounting frames available
 - Flange Plates can be fitted with “Increased Safety” certified conduit hubs or cable glands (see section J).
 - No seals required for Division 2 application.



CLASSIFICATIONS

NEC- Class I, Zone 1 AEx de IIC T5 or T6
Class I, Division 2, Groups A,B,C&D

 File No. J.I 2QOA4.AX Applied for

CEC- Class I, Zone 1 Ex de IIC T5 or T6
Class I, Division 2, Groups A,B,C&D

Environmental Protection
Type 3, 4, 4X; IP66

Ambient Temperature Range
+40°C (+104°F) Max.
-20°C (-4°F) Min.

Applications

The series 8146/5 Breaker Panelboards provide a switching system and short circuit protection for feeder and branch circuits to control either resistive or inductive loads. Applications would be heating, lighting, heat tracing and motor circuits in refineries, chemical and petrochemical plants and other process industries. They are available with or without Main Disconnect. To provide adequate short circuit protection, properly sized Class J fuses must be installed in the circuit upstream for protection of the Main Disconnect Switch.

Quick and Easy Access to Breaker

Modular “increased safety” enclosures made of FRP for indoors and outdoors, damp, wet corrosive and hazardous locations

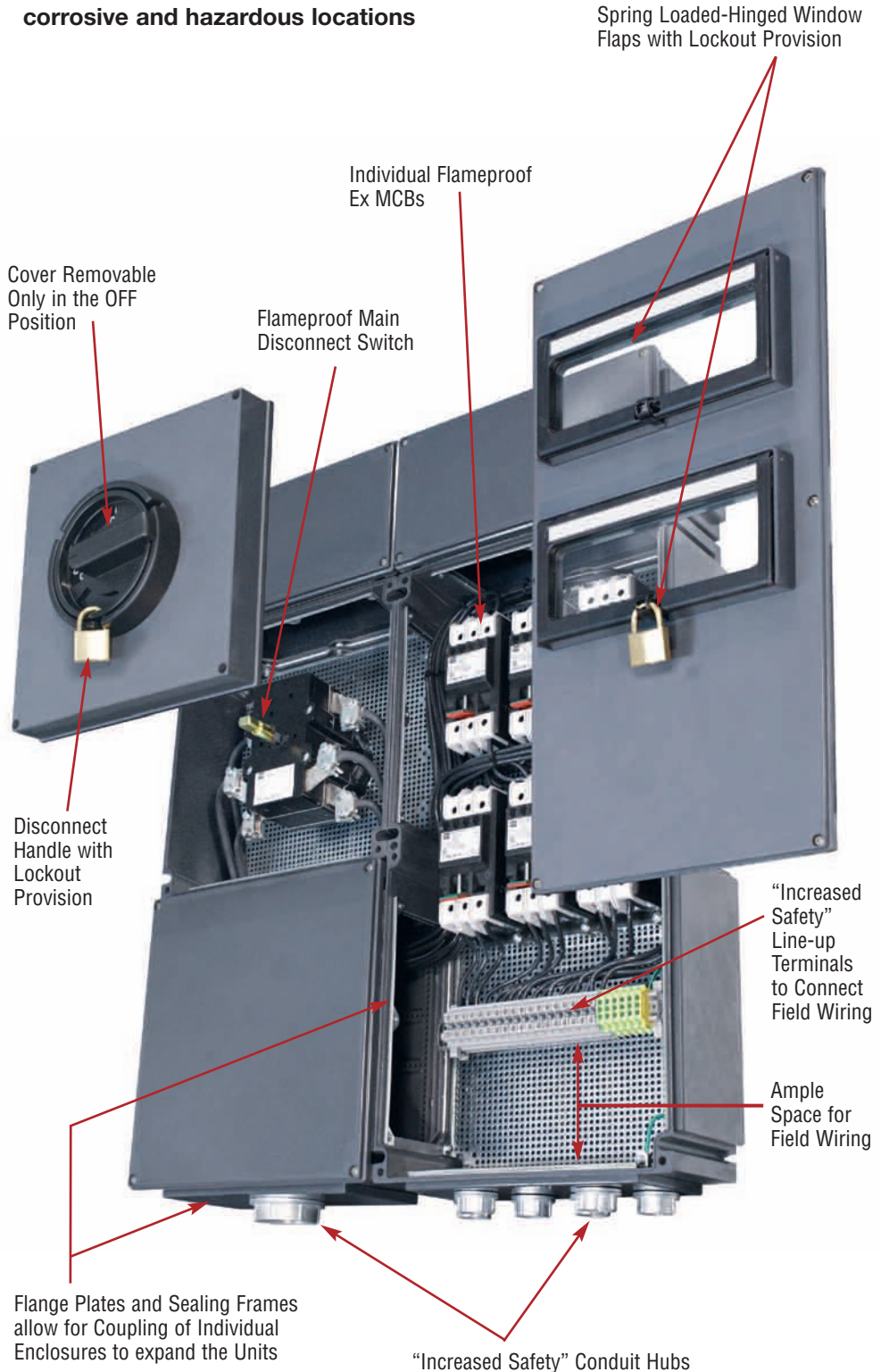

BREAKER PANELBOARDS FOR HAZARDOUS & CORROSIVE ENVIRONMENTS

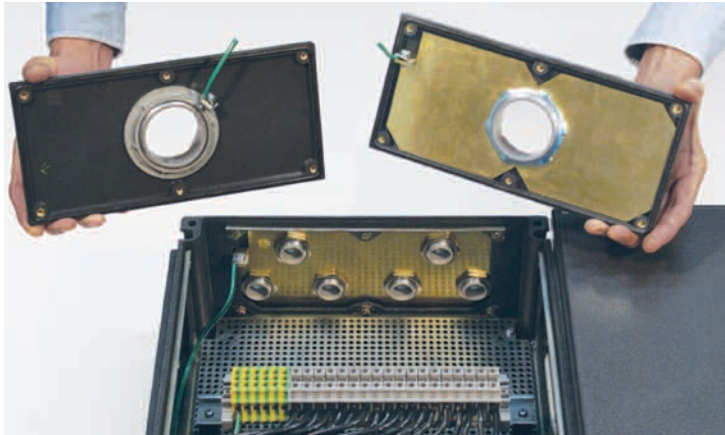

Conduit hubs or cable glands can be installed with back-up bonding plates, as shown above or with “increased safety” grounding locknuts which are interconnected with green jumper wire and also connected to the ground system.

For details see page C3, and for spacing see page C4.

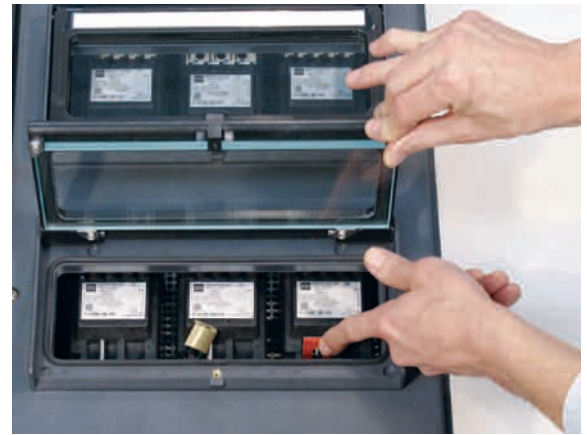

Springloaded - hinged window flaps allow easy viewing and quick access to breakers without opening the enclosure.

Individual breakers and the window flaps can be padlocked.

Max. Number of Ex MCBs Under One Window Flap	Ex MCBs
6	1 pole
4	2 pole
3	3 pole

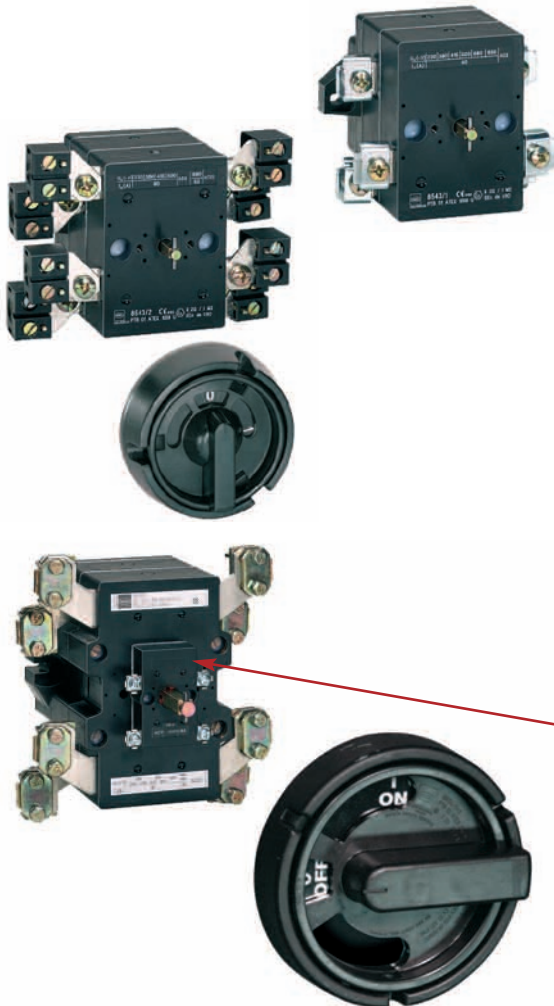

Technical Data of Main Disconnect Switches			
Type	Voltage ac	Amperage	Back-Up Fuse J
8543/1	600	40	60 A max.
8543/2	600	63	100 A max.
8548/1	600	125	200 A max.

The Disconnect Switches are made of FRP to safely contain the pressure generated by an internal explosion.

Optional auxiliary contacts are available.

THERMAL-MAGNETIC Ex MCBs TO UL 489 & CSA C22.2 No.5



CLASSIFICATIONS of Breaker

NEC

Class I, Zone 1, AEx de IIC T5 or T6
Class I, Div. 2, Groups A, B, C & D

CEC

Ex de IIC T5 or T6
Class I, Div. 2, Groups A, B, C & D



Certified File No. 171050

FEATURES

- Method of Protection: Flameproof
1, 2 and 3 Pole with Thermal -
Magnetic Branch Circuit Protection
- Design to UL 489 and
CSA-C22.2 No. 5-02
- Options: Shunt Trip
- Breakers are not temperature
compensated



1 Pole Ex MCB, 8562/51 Series			
Amp Rating at Ta = 25°C	Catalog Number		
	120/240 Vac, 10 kAIC	277 Vac, 10 kAIC	60 V, 0-60 Hz, 5kAIC
0.2	8562/51-1420-002	8562/51-1430-002	N/A
0.3	8562/51-1420-003	8562/51-1430-003	N/A
0.5	8562/51-1420-005	8562/51-1430-005	N/A
0.75	8562/51-1420-008	8562/51-1430-008	N/A
1.0	8562/51-1420-010	8562/51-1430-010	8562/51-1410-010
1.6	8562/51-1420-016	8562/51-1430-016	8562/51-1410-016
2	8562/51-1420-020	8562/51-1430-020	8562/51-1410-020
3	8562/51-1420-030	8562/51-1430-030	8562/51-1410-030
4	8562/51-1420-040	8562/51-1430-040	8562/51-1410-040
5	8562/51-1420-050	8562/51-1430-050	N/A
6	8562/51-1420-060	8562/51-1430-060	8562/51-1410-060
8	8562/51-1420-080	8562/51-1430-080	8562/51-1410-080
10	8562/51-1420-100	8562/51-1430-100	8562/51-1410-100
13	N/A	N/A	8562/51-1410-130
15	8562/51-1420-150	8562/51-1430-150	N/A
16	8562/51-1420-160	8562/51-1430-160	8562/51-1410-160
20	8562/51-1420-200	8562/51-1430-200	8562/51-1410-200
25	8562/51-1420-250	8562/51-1430-250	8562/51-1410-250
30	8562/51-1420-300	N/A	N/A
32	8562/51-1420-320	N/A	N/A
40	8562/51-1420-400	N/A	N/A

2 Pole Ex MCB, 8562/52 Series		
Amp Rating at Ta = 25°C	Catalog Number	
	120/240 Vac, 10 kAIC	480Y/ 277 Vac, 10 kAIC
0.2	8562/52-2420-002	8562/52-2430-002
0.3	8562/52-2420-003	8562/52-2430-003
0.5	8562/52-2420-005	8562/52-2430-005
0.75	8562/52-2420-008	8562/52-2430-008
1.0	8562/52-2420-010	8562/52-2430-010
1.6	8562/52-2420-016	8562/52-2430-016
2	8562/52-2420-020	8562/52-2430-020
3	8562/52-2420-030	8562/52-2430-030
4	8562/52-2420-040	8562/52-2430-040
5	8562/52-2420-050	8562/52-2430-050
6	8562/52-2420-060	8562/52-2430-060
8	8562/52-2420-080	8562/52-2430-080
10	8562/52-2420-100	8562/52-2430-100
15	8562/52-2420-150	8562/52-2430-150
16	8562/52-2420-160	8562/52-2430-160
20	8562/52-2420-200	8562/52-2430-200
25	8562/52-2420-250	8562/52-2430-250
30	8562/52-2420-300	N/A
32	8562/52-2420-320	N/A
40	8562/52-2420-400	N/A

3 Pole Ex MCB, 8562/53 Series		
Amp Rating at Ta = 25°C	Catalog Number	
	240 Vac, 10 kAIC	480Y/ 277 Vac, 10 kAIC
0.2	8562/53-3420-002	8562/53-3430-002
0.3	8562/53-3420-003	8562/53-3430-003
0.5	8562/53-3420-005	8562/53-3430-005
0.75	8562/53-3420-008	8562/53-3430-008
1.0	8562/53-3420-010	8562/53-3430-010
1.6	8562/53-3420-016	8562/53-3430-016
2	8562/53-3420-020	8562/53-3430-020
3	8562/53-3420-030	8562/53-3430-030
4	8562/53-3420-040	8562/53-3430-040
5	8562/53-3420-050	8562/53-3430-050
6	8562/53-3420-060	8562/53-3430-060
8	8562/53-3420-080	8562/53-3430-080
10	8562/53-3420-100	8562/53-3430-100
15	8562/53-3420-150	8562/53-3430-150
16	8562/53-3420-160	8562/53-3430-160
20	8562/53-3420-200	8562/53-3430-200
25	8562/53-3420-250	8562/53-3430-250
30	8562/53-3420-300	N/A
32	8562/53-3420-320	N/A
40	8562/53-3420-400	N/A



FOR BREAKER PANELS SERIES 8146/5

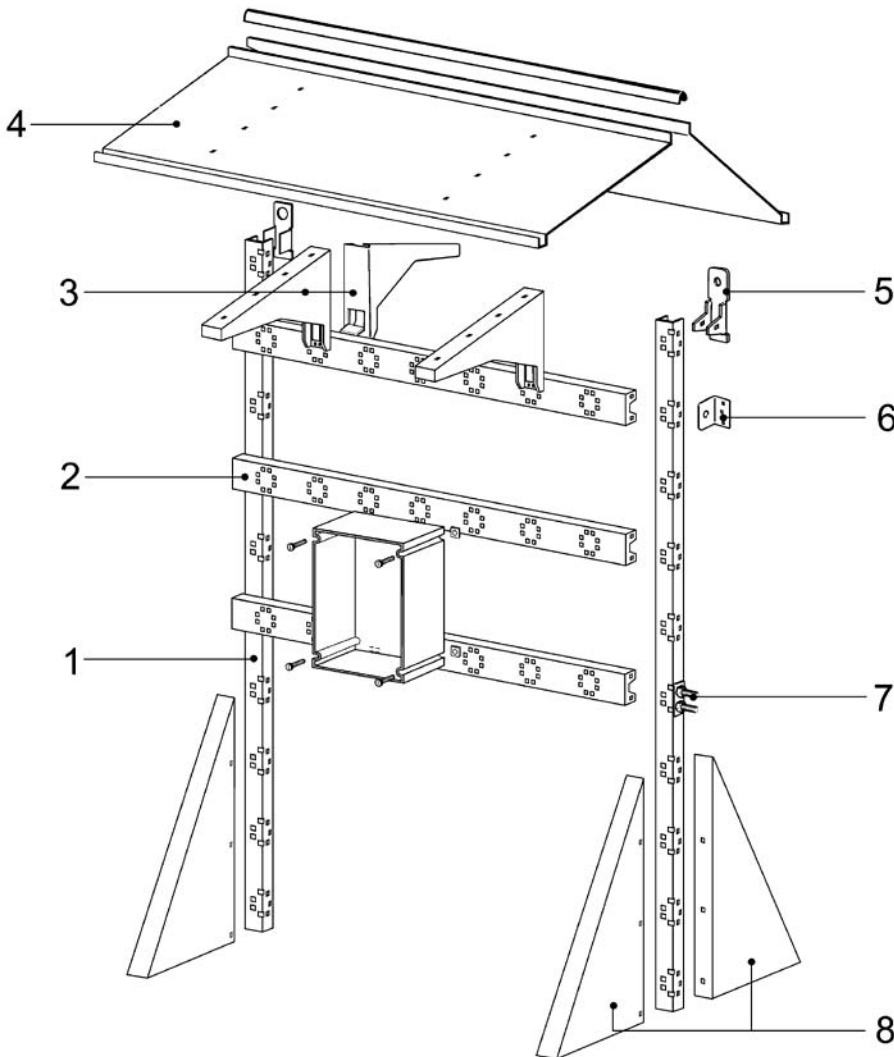

1. Vertical Supports
2. Horizontal Supports
3. Bracket for Roof Attachment
 - To secure roof
 - Can be used to mount a luminaire.
 - See Catalog Section B.
4. Roof
 - For additional protection of the breaker panel from the elements.
5. Brackets
 - End piece for transportation and wall mounting. Possible on top and bottom.
6. Fixing Angle Brackets
 - For wall mounting (on left and right side)
7. Bonding terminal
8. Triangle Support
 - Free standing
 - Can be fixed to the floor

Wall Mounting Frame for Breaker Panel shown on page H5.

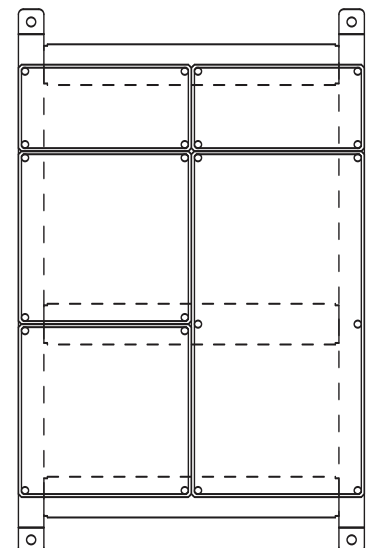
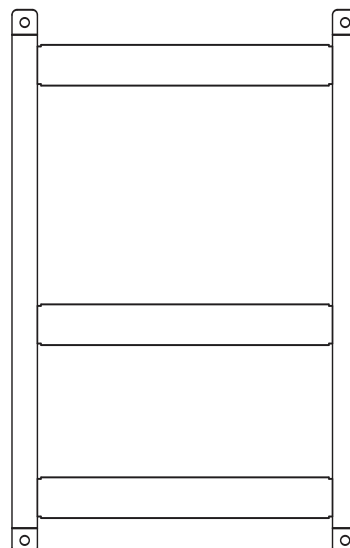

R. STAHL INC. would welcome the opportunity to quote custom designed breaker panels. Contact our engineering department with your specific requirements

DIMENSIONS

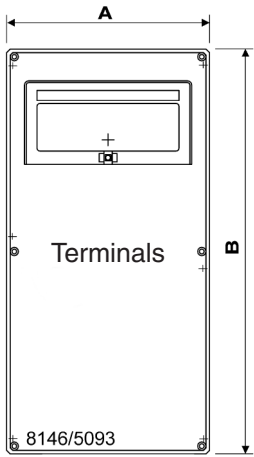

Layout without Disconnect Switch

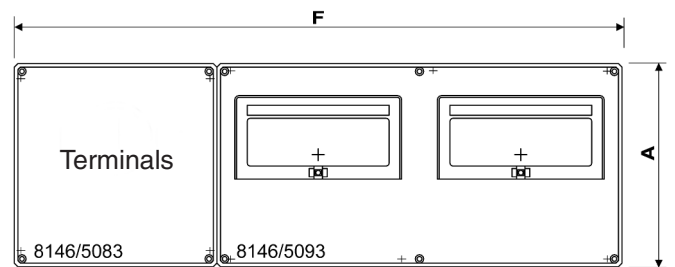
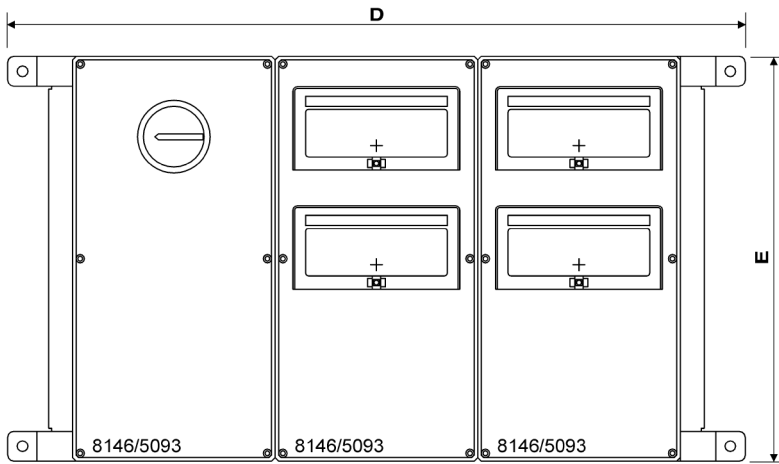
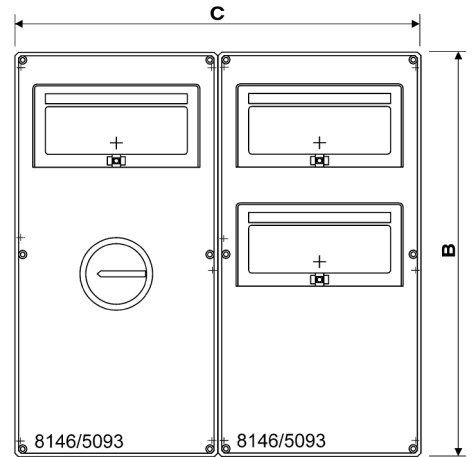
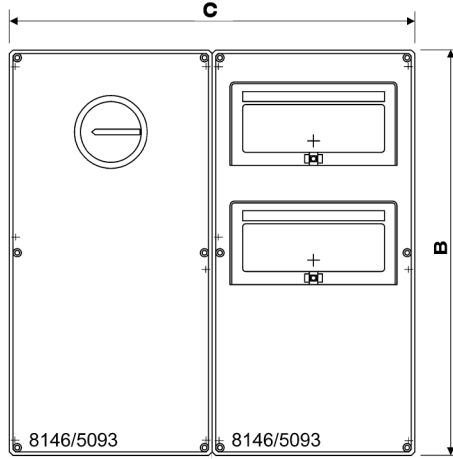

Layout without Disconnect Switch

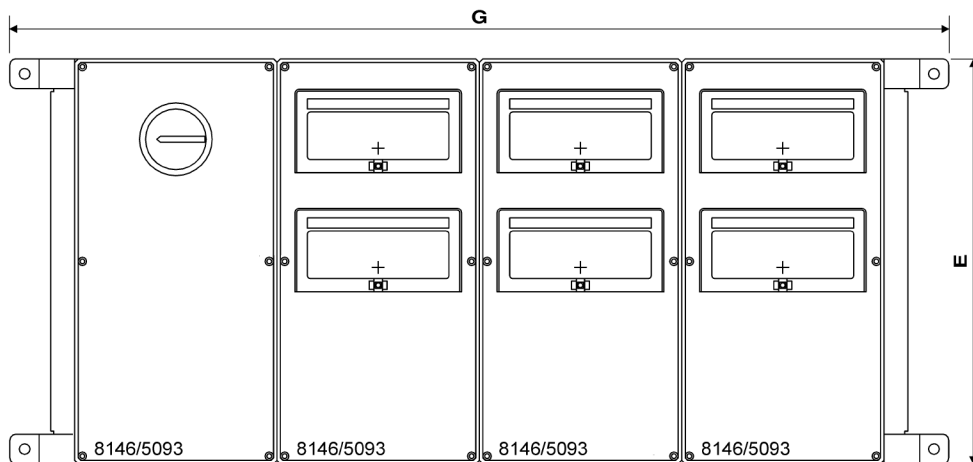
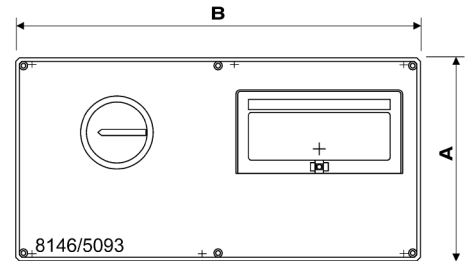

8146/5 Panelboard Dimensions	
Callouts	mm / inches
A	340.50 / 13.41
B	681.50 / 26.83
C	682.00 / 26.85
D	1236.00 / 48.66
E	684.00 / 26.93
F	1023.00 / 40.28
G	1578.00 / 62.13