



09404E00

The single-battery-supplied emergency lamps of the ECOLUX 6608 lighting series are employable as safety lighting in accordance EN 60 598.

Emergency Light Fittings for Fluorescent Lamps Series ECOLUX 6608

- For use in
 - Zone 2
 - Zone 21 and Zone 22
- For fluorescent lamps 2 x 18 W and 2 x 36 W
- With electronic ballast and integrated microprocessor controlled emergency lighting electronics
- For emergency light operation periods of 1.5 or 3 hrs
- Operating types
 - continuous circuit
 - continuous circuit with switchable emergency light blocking mechanism
- Intelligent charging method
- Battery case which can be opened separately for easy change of batteries by means of plug-type contacts
- Housing made of glass-fibre reinforced polyester resin, diffuser cover made of shockresistant polycarbonate
- Housing sealed with quick-action fasteners

Zonen 2, 21 & 22

Selection table				
Version	Lamps	Lamp control	Ordering code	Weight kg
ECOLUX 6608 Zone 2, Zone 21, Zone 22	2 x 18 W	2-channel	6608/522-9..7-2240	6,500
	2 x 36 W	2-channel	6608/542-9..7-2240	8,000
Add. to ordering code				
Through wiring	Standard: Without		6608/...-0...-....	
	Special: With 4-cores		6608/...-4...-....	
	Special: With 6-cores		6608/...-6...-....	
Cable entries	Standard: M 25 x 1,5 1 cable lead-in 2 plugs		6608/...-1...-....	
	Special: M 20 or M 25 made of plastic or metal Plain text specification		6608/...-9...-....	
Note	The lamps are supplied without fluorescent lamps and installation parts. These parts must be ordered separately as accessories!			

Technical Data	
Explosion protection	
Gas explosion protection	Zone 2: II 3 G EEx nA II T4
Dust explosion protection	Zone 21: II 2 D IP 66 T80 °C Zone 22: II 3 D IP 66 T80 °C
Certificates	
Gas explosion protection	Zone 2: BVS 03 E 093
Dust explosion protection	Zone 21: BVS 03 ATEX 094 X Zone 22: BVS 03 E 093
Marking	CE 0102
Rated voltage	AC: 220 V - 10 % ... 254 V + 6 %; 50 Hz / 60 Hz
Lamps	2 x 18 / 20 W, 2 x 36 / 40 W
Protection class	I (with internal PE terminal)
Ambient temperature	
Standard operation	- 20 °C ... + 50 °C
Battery operation	- 5 °C ... + 50 °C charge - 20 °C ... + 50 °C discharge
Connection	Connection facility Connection terminals L1, L2, L3, N, PE, L' 2.5 mm ² fine-wire / single-wire L' = charging phase, must not be switched
Through wiring	Lamps available with internal wiring, 4- or 6-core; Cross-sectional area 2.5 mm ² for max. 16 A
Cable entries	Standard Connection side: 1 cable gland M 25 x 1.5 and 1 stopping plug M 25 x 1.5; Opposite side: 1 stopping plug M 25 x 1.5 Special M 20 made of plastic or metal
Material	
Housing	Polyester resin, glass-fibre reinforced, colour white, similar to RAL 9010
Cover	Polycarbonate, shock-resistant, aromatic-resistant lacquer possible
Gaskets	Foam polyurethane sealing in the diffuser cover
Quick-action fasteners	Polyamide, glass-fibre reinforced
Installations parts	Polyester resin, glass-fibre reinforced, white, similar to RAL 9010



Technical Data	
Degree of Protection	IP 66 / IP 67 (IP 64 with Breathing gland 8162)
Cover fixing	Quick-action fasteners to be opened using a screwdriver; Diffuser cover can be swivelled by means of a hinge
Light guides	Standard Broad reflective, internal reflector of light fitting painted white. Colour: Signal white RAL 9003; lateral glare is limited by the lamp diffuser cover. Special Auxiliary reflector (easily mountable), narrow-angle / wide-angle shining, aluminium anodised and polished.
Switch-off	Optional When opening the diffuser cover When opening the closure mechanism on one of the quick-action fasteners, the voltage to the ballast is switched off at all poles; The contacts of the switching element are forced-opening contacts, switch-on again when lamp diffuser cover and quick-action fastener are closed. In the case of a lamp defect In the case of a lamp defect, the electronic ballast automatically switches the power supply of the defective lamp off.
Version of light fitting	2-lamp 2-lamp without auxiliary reflector with auxiliary reflector
Accuracy class acc. to LitG	B21 B31
Battery set	
Type	NiCd battery, gas-tight, the battery housing mounted on the lamp
Capacity	7 Ah
Operating voltage	6 V
Charging battery set	Open the battery housing; After loosening one of the plug contacts, the battery unit can be removed from the housing.
Emergency light electronics	
Construction	Emergency light electronics is integrated in a housing together with the electronic ballast
Options	The emergency light electronics are designed for: Continuous circuit or continuous circuit with switchable emergency light blocking mechanism
Interference suppression	In accordance with DIN EN 55 015
Operating test	Weekly verification of the emergency light function; Battery errors and lamp defects are pinpointed and indicated via the red LED.
Emergency light duration test	Automatic emergency light lighting-duration test function integrated in the lamp; Deactivation of the function: Insert jumper between terminals 9 and 12 Activation of the function: Remove jumper between terminals 9 and 12 If the jumper on terminals 9 and 12 is removed, then the test function is activated as soon as the lamp is connected to the mains; a built-in timer function reruns the necessary tests at intervals of 3 months using the following test: The lamp is operated in emergency light mode over 2/3 of the nominal operation time; if the lamp is switched off via the low-discharge protection mechanism before the elapse of this time, then the battery unit is no longer suitable for utilisation in emergency light systems; this is indicated via the red LEDs.



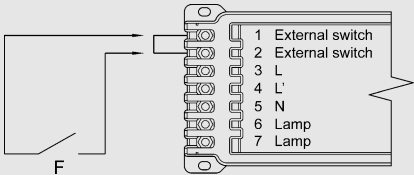









Technical Data

Function indicators	1 red light-emitting diode and 1 green light-emitting diode; integrated in the reflector sheet metal plate;			
	Anzeigen			
	LED	Display	Function	
Operation modes	Green	ON	Charging current is flowing, everything ok	
		Blinking	1 : 1	Automatic lighting-duration test is running
		Flashing	1 : 10	Automatic function test is running
	Red	ON	Emergency light lighting-duration test not passed; change of battery necessary	
		Blinking	1 : 1	Battery discharged; not ready for operation
		Flashing	1 : 10	Battery defective
	<p>On delivery, the lamp fitting is wired in a continuous circuit; via removal of the jumper on the terminals 1 and 2 of the emergency light electronic hardware and connection of a remote switch F, the lamp fitting is converted to continuous circuit with switchable emergency light blocking mechanism.</p> <div style="display: flex; align-items: center; justify-content: center;">  <div style="margin-left: 20px;"> <p>Remove jumper 1 / 2</p> </div> </div> <p style="text-align: right; font-size: small;">09373E01</p>			
Maintained operation	In the case of a possible failure of the power supply for the general lighting, the lamp only switches to emergency lighting operation when the remote switch F is switched on.			
Maintained operation with switchable emergency lighting	The emergency light is centrally switched to "ready for operation" or "not ready for operation" by means of the remote switch, e.g. depending on the system operating times; the remote switching is effected via an external switch with a floating make contact.			
Battery charging	Current-regulated constant-current charging, duration 20 h, there after changeover to trickle charging.			
Deep discharge protection	When $U_{Batt} = 1 \text{ V} / \text{cell}$ (3 V); the emergency light automatic mechanism switches off the lamp automatically (DIN VDE 0108)			
Emergency light operation	During emergency light operation only one lamp is operated. This results in reduced lighting power (see emergency light operation time)			
Emergency light duration	1.5 h / 3 h at battery capacity 7 Ah			
Changeover voltage	From mains to battery operation	For $U < 0,6 \times U_N$		
	From battery to mains operation	For $U > 0,9 \times U_N$		
Light power during emergency light operation	Emergency light operating duration		Emergency light lighting power	
	1,5 h	18 / 20 W 90 %	36 / 40 W 45 %	
	3 h	45 %	25 %	







Accessories and spare parts

Designation	Illustration	Description	Ordering code	Weight kg
Fluorescent lamp	 <small>04936E00</small>	Two pin base \varnothing 26 mm Light colour: Universal white		
		18 W 1100 lm	4617220	0,100
		36 W 2600 lm	4617210	0,200
		58 W 4100 lm	4617200	0,283

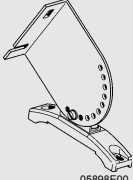
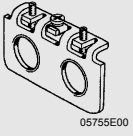
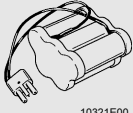
Accessories and spare parts				
Designation	Illustration	Description	Ordering code	Weight kg
Diffuser cover		For lamp 18 / 20 W	6600001050	0,500
		For lamp 36 / 40 W	6600002050	0,800
		For lamp 58 / 65 W	6600003050	1,000
Switch		Switch element 8080/1-3-L, 2 NC	8080006600	0,025
Ballast		1 x 18 W 1-channel	3656680	0,160
		1 x 36 W 1-channel	3657090	0,338
Emergency light electronics		6443/341-1 1 x 36 W	6443803010	1,150
Lamp-holder		Lamp-holder for 2-pin base lamps G 13	3856630	0,008
Mounting rail		For variable mounting 1 pair	6600801750	0,420
Mounting clamp bracket		Installation clamp mounted on installation rail for variable mounting distances	1 pair 6600802750	0,150
M8 ring bolts		M 8, to mount directly into inserts, 1 pair	6000803900	0,107
Wall-mounting bracket		For pole-mounting fitting with extension tube 1300 mm in length, \varnothing 42 mm		
		(for pipe clamp R1 1/2")	4637490	6,000
Ceiling mounting bracket		For ceiling mounting of light fitting 1 pair	6600803750	0,230
Pipe clamps		with mounting rail for variable mounting distances; material: stainless steel		
		R 1 1/4" (\varnothing 42 mm)	6600805260	1,100
		R 1 1/2" (\varnothing 48 mm)	6600801260	1,100
		R 2" (\varnothing 60 mm)	6600802260	1,300
Mounting set „Grid cable rack“		For grid cable racks, with wire diameter 6 mm; with mounting rail for variable mounting distance; Material: Stainless steel	6600803260	0,775

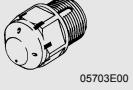

Accessories and spare parts					
Designation	Illustration	Description	Ordering code	Weight kg	
Ceiling and wall-mounting bracket	 <small>05898E00</small>	With mounting rail for variable mounting distances; Material: Stainless steel Lamp can be swivelled in steps of 15°			
		1 pair	6600804260	1,200	
Adapter plates	 <small>05755E00</small>	For earthing continuity when metal glands are used			
		1 x M 20 x 1.5	1 pc	6000815550	0,070
		1 x M 25 x 1.5	1 pc	6000816550	0,070
		1 x NPT 1/2"	1 pc	6000817550	0,070
		1 x NPT 3/4"	1 pc	6000818550	0,070
		2 x M 20 x 1.5	1 pc	6000819550	0,060
		2 x M 25 x 1.5	1 pc	6000820550	0,060
		2 x NPT 1/2"	1 pc	6000821550	0,060
Battery unit	 <small>10321E00</small>	NiCd-battery	7 Ah / 6 V	1 pc	
Reflectors	 <small>05324E00</small>	For later installation, broad deep-beam			
		For 2-lamp light fittings 18 W / 20 W	6030901580	0,110	
		For 2-lamp light fittings 36 W / 40 W	6030902580	0,234	
Cable gland	 <small>05864E00</small>	in moulded plastic			
		8161/5-M 20-13	1 piece	8161077010	0,012
		8161/5-M 20-13	50 pieces	8161025030	0,600
		8161/5-M 25-17	1 piece	8161078010	0,016
		8161/5-M 25-17	50 pieces	8161026030	0,850
Stopping plug	 <small>04840E00</small>	in moulded plastic			
		8290/3-M 20 x 1.5	1 piece	8290008590	0,004
		8290/3-M 20 x 1.5	100 pieces	8290045590	0,600
		8290/3-M 25 x 1.5	1 piece	8290009590	0,006
		8290/3-M 25 x 1.5	100 pieces	8290046590	0,800
Breathing gland	 <small>05703E00</small>	for installation in light fittings; in moulded plastic; without locknut			
		Thread: M 25 x 1.5	1 unit	8162001020	0,010
		Thread: M 25 x 1.5	20 units	8162002020	0,200

Emergency Light Fittings for Fluorescent Lamps Series ECOLUX 6608

Dimension drawings (all dimensions in mm) - subject to alterations

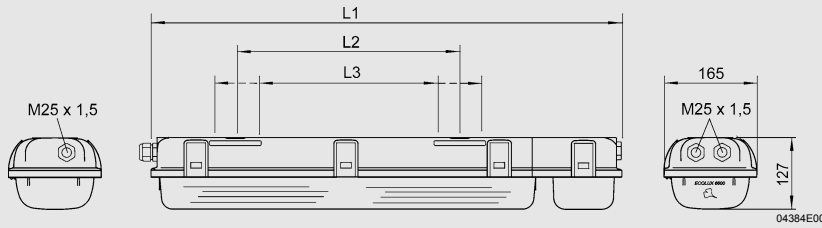

Dimensions	Light fitting	
	18 / 20 W	36 / 40 W
L1	830	1440
L2 ¹⁾	400	800
L3 ²⁾	340 ... 460	680 ... 920

¹⁾ Fixed mounting distance
²⁾ Variable mounting distance

Emergency light fittings ECOLUX 6608, 18 W, 36 W

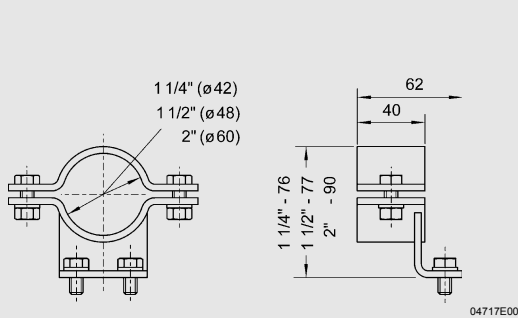

Pipe clamp

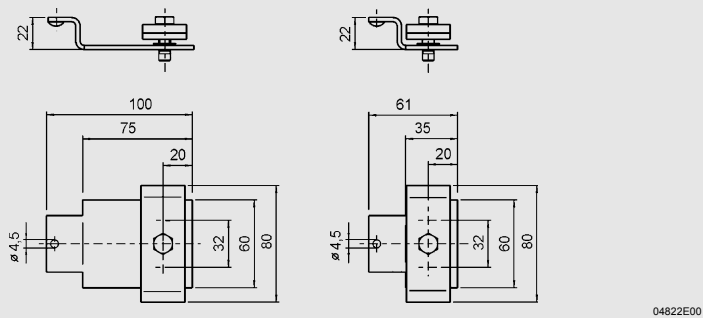

Mounting set grid cable rack

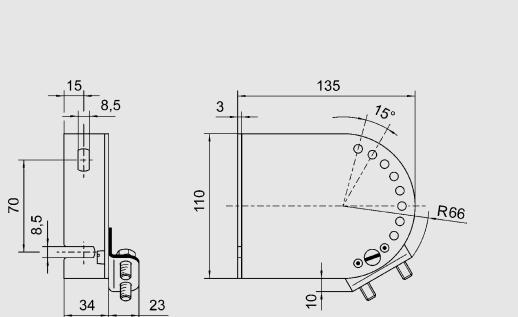

Ceiling- and wall-mounting bracket

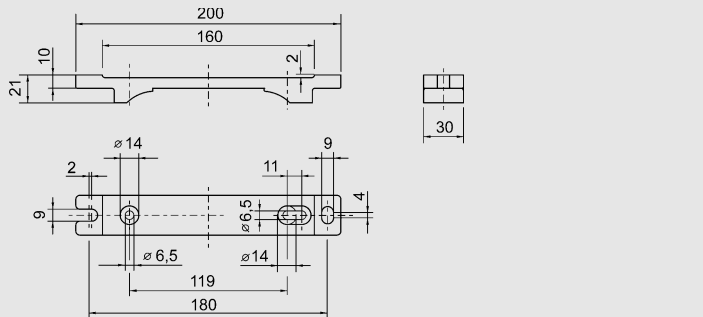

Ceiling mounting bracket

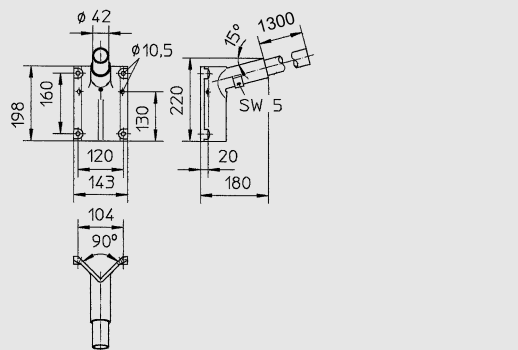

Wall mounting bracket for pole-mounting version

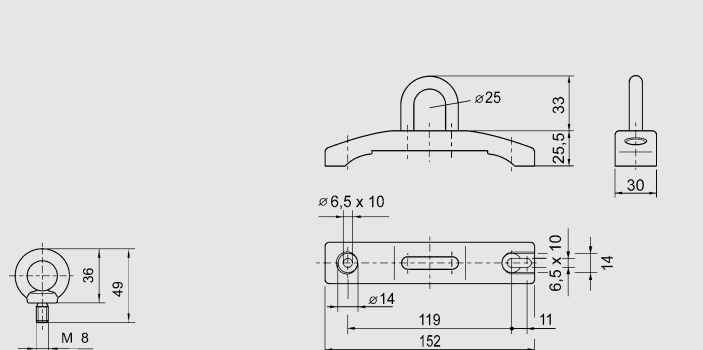

Ring bolt

Mounting clamp bracket

Installation accessories

We reserve the right to make alterations to the technical data, weights, dimensions, designs and products available without notice. The illustrations cannot be considered binding.

