

09845E00

STAHL

Series 8225 sheet steel enclosures and series 8264 CUBEx can be used as single enclosures and combinations. The dimensions of the enclosures are so designed that they can be combined into a large modular unit. A large number of components, such as contactors, switches, instruments and PLCs can be built into these enclosures. Naturally, customer-supplied equipment can also be incorporated into the layout. The equipment layout is designed by us to customer's requirements. Cable entry is either direct (cable glands or conduit entries) or indirect via an EEx e housing (stud-type or conductor bushings) - see catalogue section 12.

#### EEx d Enclosures Flameproof Encapsulation

- Explosion protection to
  - CENELEC
  - IEC
- Can be used in Zone 1 and Zone 2
- Enclosure in sheet steel or aluminium
- Enclosures can be combined (modular system)
- Available as empty enclosures or as completely fitted and wired control and distribution units
- Cable entries available:
  - direct:
    - cable glands, conduit
  - indirect (via EEx e enclosure):
    - stud-type bushing,
    - conductor bushing

# Zones 1 & 2



01727E00

**8225 + 8125**



09859E00

**CUBEx 8264 + 8125**



01738E00

**GUB**

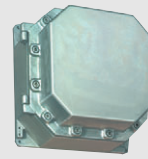

01729E00

**8261**



01784E00

**8218**



09852E00

**8214**

### Product range

Our product range contains a wide variety of flameproof enclosures which offer a selection of sizes, designs and materials. The 8225 sheet steel enclosure series and the cast metal enclosures CUBEx series 8264 are designed for single installations as well as for large distribution units. The cast metal enclosures in the GUB and 8261 series and the 8214 and 8218 panel mounting type enclosures are intended for single installations.

### Flameproof enclosures

The "flameproof" type protection 'd' is based on the principle that electrical components which may cause sparks or arcing in normal operation (switches, contactors etc.) are in an enclosure constructed so that it will contain an explosion of flammable gas or vapour and will not permit ignition of a surrounding explosive atmosphere. Further, the temperature of the outside surface of the enclosures must not exceed the prescribed temperature limit for the appropriate temperature class. That means, the heat loss from the components fitted must not exceed a specified value.

### Direct cable entry

Cables can be brought into and out of flameproof enclosures directly. Flameproof cable glands or conduit with seals must be used for this purpose.

### Indirect cable entry

Cables can also be brought in and out of flameproof enclosures via a terminal chamber with "increased safety" protection type. The cable is normally brought into the chamber via a cable glands, series 8161, however other methods of entry are possible. The cable passes into the flameproof enclosure via insulated, flameproof, stud-type or conductor bushings, set into the enclosure wall.

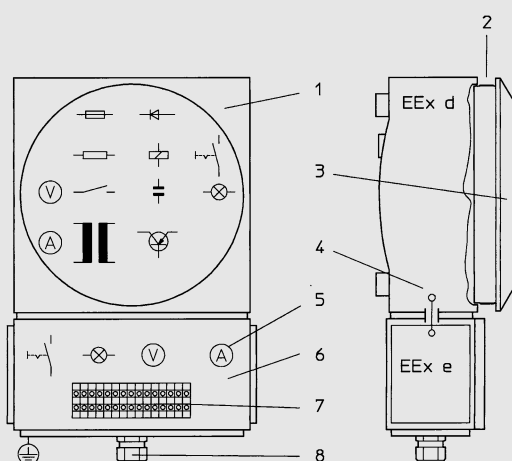

08866E00

Schematic representation of a flameproof enclosures with a terminal chamber

- 1 Enclosure EEx d, "flameproof" construction, pressure with standing
- 2 Lengths and clearances of joint "paths" comply with manufacturing regulations EN 50 018
- 3 Cover
- 4 Conductor bushing, pressure tight, flameproof, increased insulation paths
- 5 Indication and control devices in EEx d/e
- 6 Terminal chamber EEx e, ≥ IP 54
- 7 EEx e terminals, indication and control devices in EEx d/e
- 8 Cable entry
  - cable glands, series 8161
  - bell mouthed glands
  - cable dividing boxes

